



# 235/270 MANURE SPREADER

# PARTS BOOK



Revision #03

235 Starting Serial #313398

270 Starting Serial #314072

HSMFG0213

Part #59748

Manufactured By

## H&S MANUFACTURING CO., INC.

P.O. BOX 768 (715) 387-3414 FAX (715) 384-5463

MARSHFIELD, WISCONSIN 54449

# CONTENTS

Instructions for Ordering Parts .....	1
Figure 1 - Beater and Pan Assembly .....	2-3
Figure 2 - Hub, Spindle and Box Parts .....	4-5
Figure 3 - Front Shield and Drive Assembly .....	6-9
Figure 4 - Back Shield and Drive Assembly .....	10-13
Figure 5 - Hydraulic Endgate .....	14-15
Figure 6 - Apron Chain Assembly .....	16
Figure 7 - Hydraulic Endgate Cylinder .....	17
Figure 8 - PTO .....	18
Figure 9- Optional Second Beater .....	19
Figure 10 -Gearbox .....	20-23
Figure 11 -4 Hose Hydraulic Drive Assembly .....	24-25
Figure 12 -2 Hose Hydraulic Drive Assembly .....	26-27
Figure 13 - Hydraulic Cylinder .....	28-29
Parts Notes .....	30

# **INSTRUCTIONS FOR ORDERING PARTS**

All service parts should be ordered through your authorized H&S dealer. He will be able to give you faster service if you will provide them with the following:

1. Model & Serial Number - Both can be located on the side of the center bearing post above jack mount.
2. All references to left or right apply to the machine as viewed from the rear.
3. Parts should not be ordered from illustration only. Please order complete part number.
4. If your dealer has to order parts - give shipping instructions:

VIA truck - large pieces (please specify local truck lines)

VIA United Parcel Service (include full address)

Via FED EX (Include Full Address)

<b>H&amp;S MFG. CO. INC.</b>	
MARSHFIELD, WIS.	
MOD. NO.	<input type="text"/>
SER. NO.	<input type="text"/>
DESCR.	<input type="text"/>

PLEASE RECORD NUMBERS FOR YOUR UNIT FOR QUICK REFERENCE

## **ABOUT IMPROVEMENTS**

H&S MFG. CO. INC. IS CONTINUALLY STRIVING TO IMPROVE IT'S PRODUCTS

We must therefore, reserve the right to make improvements or changes whenever it becomes practical to do so, without incurring any obligation to make changes or additions to the equipment previously sold.

# FIGURE 1

## BEATER/PAN ASSEMBLY

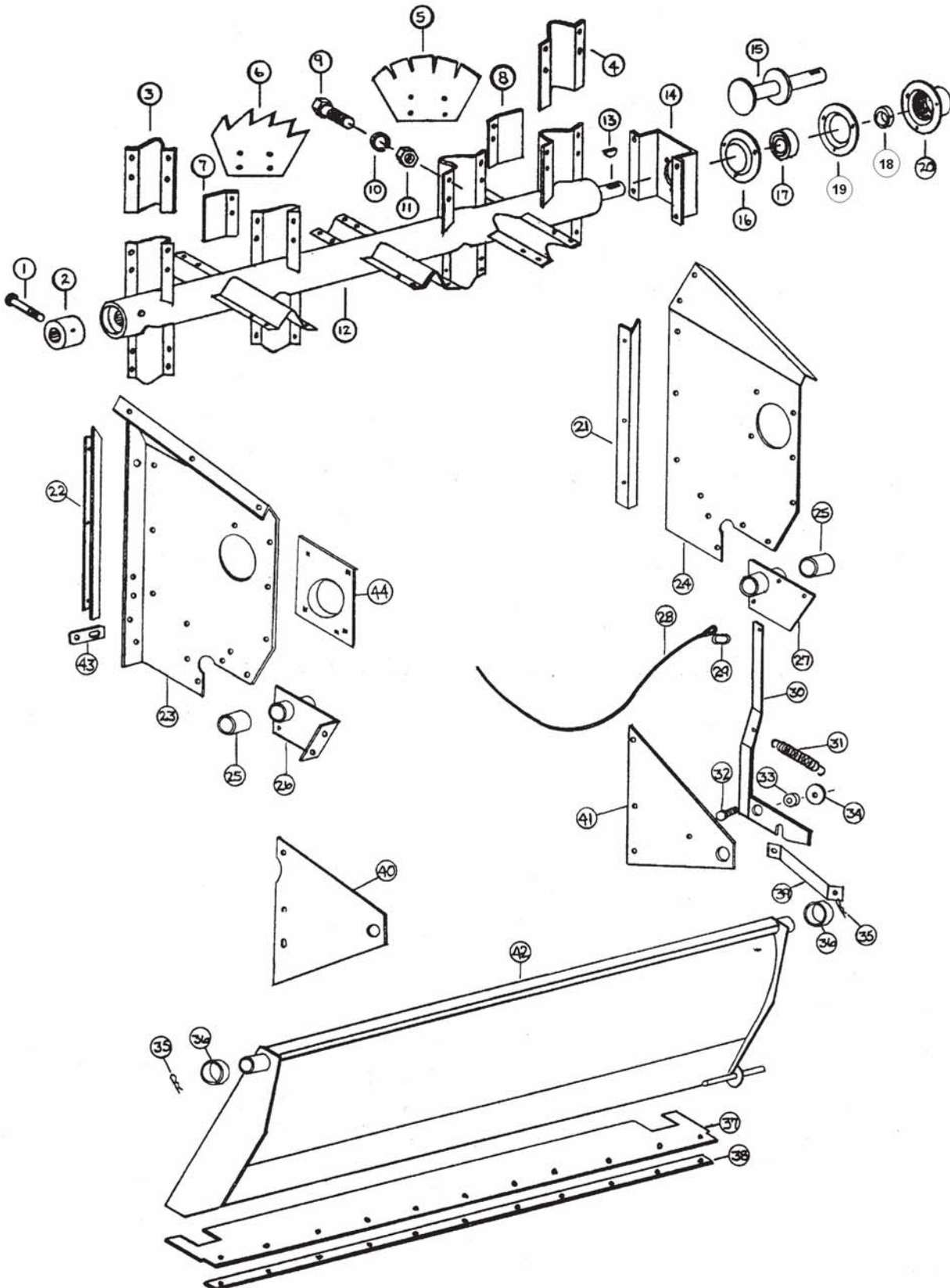

# FIGURE 1

## BEATER/PAN ASSEMBLY

<u>ITEM</u>	<u>235</u>	<u>270</u>	<u>DESCRIPTION</u>
1	YBHH10130	"	BOLT, 5/16" X 5" GR. 5
2	23N2	"	SPLINED BEATER INSERT
3	23N3	"	BEATER BLADE HOLDER LH
4	23N4	"	BEATER BLADE HOLDER RH
5	23N276	"	BEATER BLADE - HARDENED
6	23N277	"	BEATER BLADE - HARDENED
7	23N7	"	BEATER BLADE WIPER LH
8	23N8	"	BEATER BLADE WIPER RH
9	YBHH16045	"	BOLT, 1/2" X 1-1/4" GR. 5
10	YWLO16005	"	WASHER, LOCK, 1/2"
11	YNTL16005	"	HEX NUT, TOP LOCK, 1/2"-13
12	23N263	"	BEATER
13	5B9	"	3/8" X 1-1/4" WOODRUFF KEY
14	23N10	"	BEATER SHAFT SUPPORT
15	23N11	"	BEATER STUB SHAFT
16	F116	"	BEARING FLANGE (HEAVY DUTY)
17	12N122	"	BEARING W/ LOCK COLLAR ASSY.
18	12N122	"	BEARING W/ LOCK COLLAR ASSY.
19	F114A	"	BEARING FLANGE W/ ZERK 45 DEGREE
20	23N12	"	BEARING FLANGE GUARD
21	23N13	"	RH SIDE POLY HOLD DOWN
22	23N14	"	LH SIDE POLY HOLD DOWN
23	23N264	"	LH MAIN PANEL
24	23N265	"	RH MAIN PANEL
25	23N17	"	DRIVE SHAFT BUSHING
26	56271	"	DRIVE SHAFT BRACKET LH
27	56268	"	DRIVE SHAFT BRACKET RH
28	23N20	27N1	PAN TRIP ROPE
29	R31	"	CLIP
30	23N21	"	PAN TRIP LEVER
31	R27	"	SPRING
32	YBCR16010	"	CARRIAGE. BOLT, 1/2" X 1-1/2" GR. 5
33	23N23	"	TRIP LEVER SPACER
34	YWFL16005	"	WASHER, FLAT, 1/2" USS
35	YPCT06020	"	COTTER PIN, 3/16" X 2"
36	F112	"	SPACER
37	23N24	"	PAN RUBBER FLAP
38	23N25	"	PAN STRAP
39	23N267	"	PAN SUPPORT BRACE
40	23N268	"	LH PAN SUPPORT
41	23N29	"	RH PAN SUPPORT
42	23N30	"	PAN
43	23N64	"	SHIELD BRACKET
44	17G10	"	LH ANTI-WRAP GUARD

**NOTE: " MEANS SAME AS PREVIOUS MODEL**

# FIGURE 2

## SPINDLE/HUB/BOX PARTS

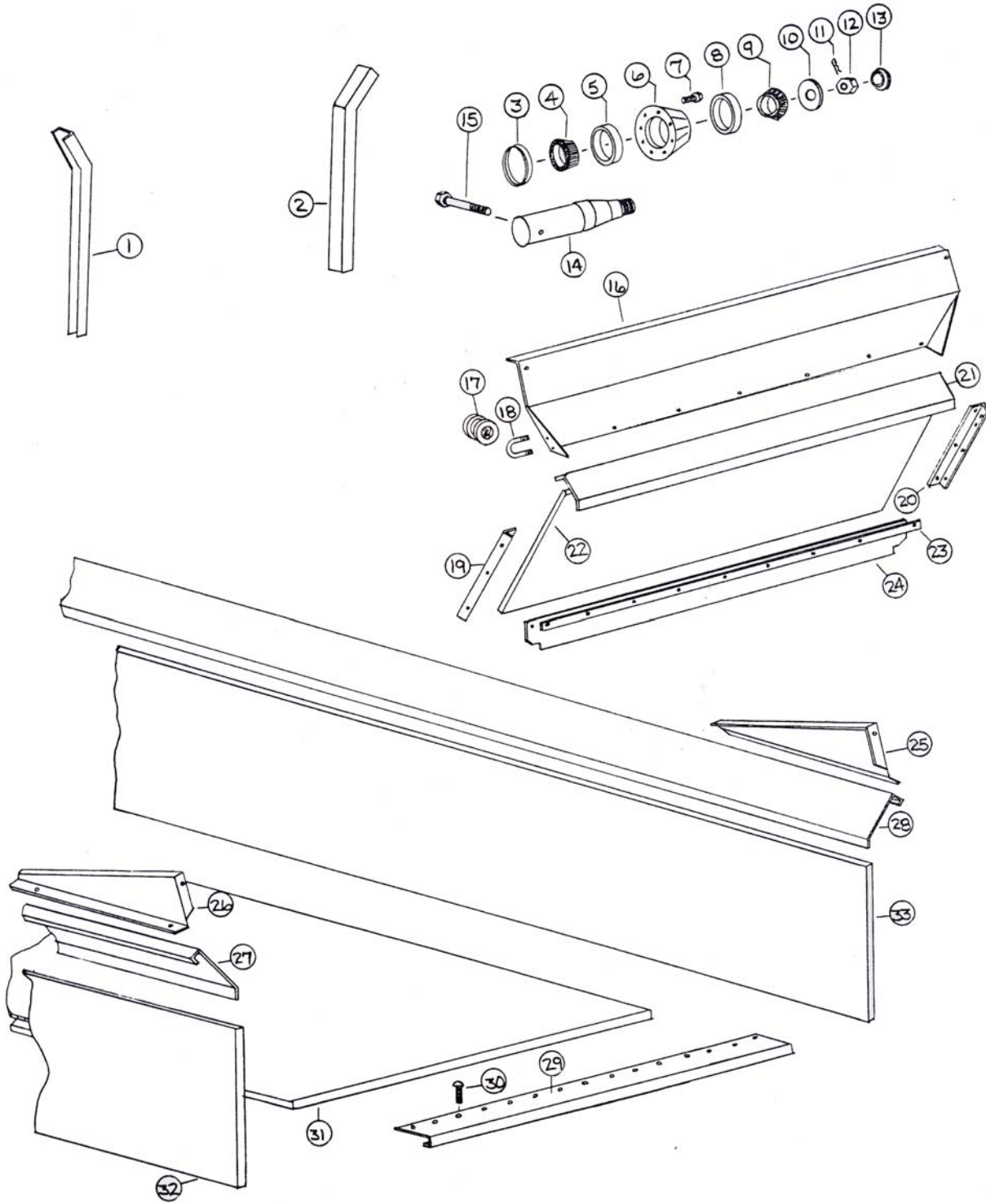



## FIGURE 2

### SPINDLE/HUB/BOX PARTS

<u>ITEM</u>	<u>235</u>	<u>270</u>	<u>DESCRIPTION</u>
1	23N31	"	RH SIDE STAKE
2	23N32	"	LH SIDE STAKE
3	B8	B90	SEAL
4	B7	B91	INNER BEARING
5	B7A	B91A	INNER RACE
6	B6	26G4A	HUB
7	B32	B93	HUB BOLT
8	B5A	B94A	OUTER RACE
9	B5	B94A	OUTER BEARING
10	YWFL28005	"	WASHER, FLAT, 7/8" USS
11	YPCT05020	"	COTTER PIN, 5/32" X 1-3/4"
12	YNSL28005	"	HEX NUT, SLOTTED, 7/8"-14
13	B2	"	HUB CAP
14	B9	27N2	SPINDLE
*	23N304	27N46	SPINDLE FOR 14 X 16.1 WHEEL
15	YBHH16130	"	BOLT, 1/2" X 4" GR. 5
16	23N34	"	FRONT FLARE
17	F33	"	ROPE GUIDE
18	YBPU08005	"	PIPE U BOLT, 1/4"-20 X 3/4" PIPE, 1-1/4" ID, 2-1/4" IL, 1-1/4" THREAD
19	23N35	"	RH GATE ANGLE
20	23N36	"	LH GATE ANGLE
21	23N176	"	FRONT FLARE SUPPORT
22	23N270A	"	FRONT GATE PLYWOOD WITH FIBERGLASS
23	23N40	"	STRAP FOR RUBBER
24	23N41	"	FRONT GATE RUBBER
25	23N42	"	SPLASH GUARD SIDE LH
26	23N43	"	SPLASH GUARD SIDE RH
27	23N177	27N24	RH SIDE FLARE
28	23N178	27N25	LH SIDE FLARE
29	23N46	"	FRONT POLY FLOOR HOLD DOWN
30	B106	"	BOLTS FOR POLY FLOOR
31	23N271	27N36	FLOOR PLYWOOD WITH POLY
32	23N272A	27N37A	RH SIDE PLYWOOD WITH FIBERGLASS
33	23N273A	27N38A	LH SIDE PLYWOOD WITH FIBERGLASS
*	12V36	"	WHEEL 14 X 16.1
*	23N179	"	WHEEL 8 X 22.5

**NOTE: " MEANS SAME AS PREVIOUS MODEL**  
**\* MEANS NOT SHOWN**

**FIGURE 3**  
**FRONT SHIELDS/DRIVE ASSEMBLY**

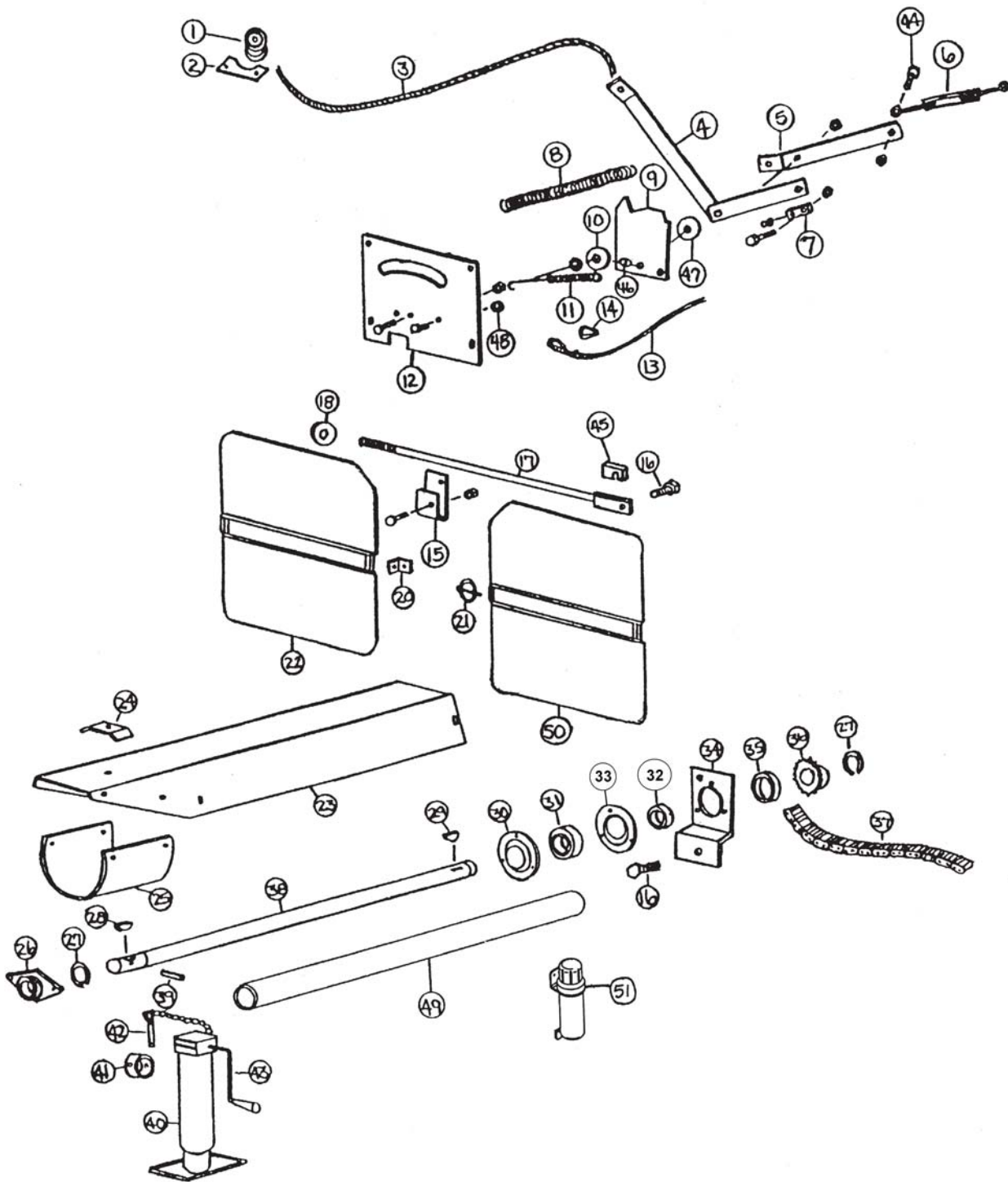



## FIGURE 3

### FRONT SHIELDS/DRIVE ASSEMBLY

<u>ITEM</u>	<u>235</u>	<u>270</u>	<u>DESCRIPTION</u>
1	F33	"	CABLE GUIDE
2	23N182	"	BRACKET
3	23N183	"	ROPE - 15'
4	23N280	"	SHIFTER LEVER
5	23N281	"	PIVOT LINK
6	F84	"	TURNBUCKLE
7	23N282	"	SHIFTER DOG
8	10R14	"	SPRING
9	23N283	"	STOP BRACKET
10	S304	"	WASHER
11	23N284	"	SHIFTER DOG SPRING
12	23N285	"	FRONT PANEL
13	23N286	27N40	CABLE
14	F44	"	CABLE LOOP
15	23N287	"	SPRING BRACKET
16	YBHH16045	"	BOLT, 1/2" X 1-1/4" GR. 5
17	23N63	"	TIGHTENER ROD
18	F129	"	WASHER
20	F92	"	SHIELD BRACKET
21	S122	"	LANYARD, CLIP PIN CABLE
22	23N305	"	FRONT SHIELD RH
23	23N66	"	SHIELD
24	23N67	"	TAILGATE HOSE BRACKET
*	HE42	"	HYDRAULIC DRIVE BRACKET
25	F54	"	SHIELD
26	12N29	"	BEARING
27	F73	"	SNAP RING

**NOTE: " MEANS SAME AS PREVIOUS MODEL**

**\* MEANS NOT SHOWN**

**FIGURE 3**  
**FRONT SHIELDS/DRIVE ASSEMBLY**

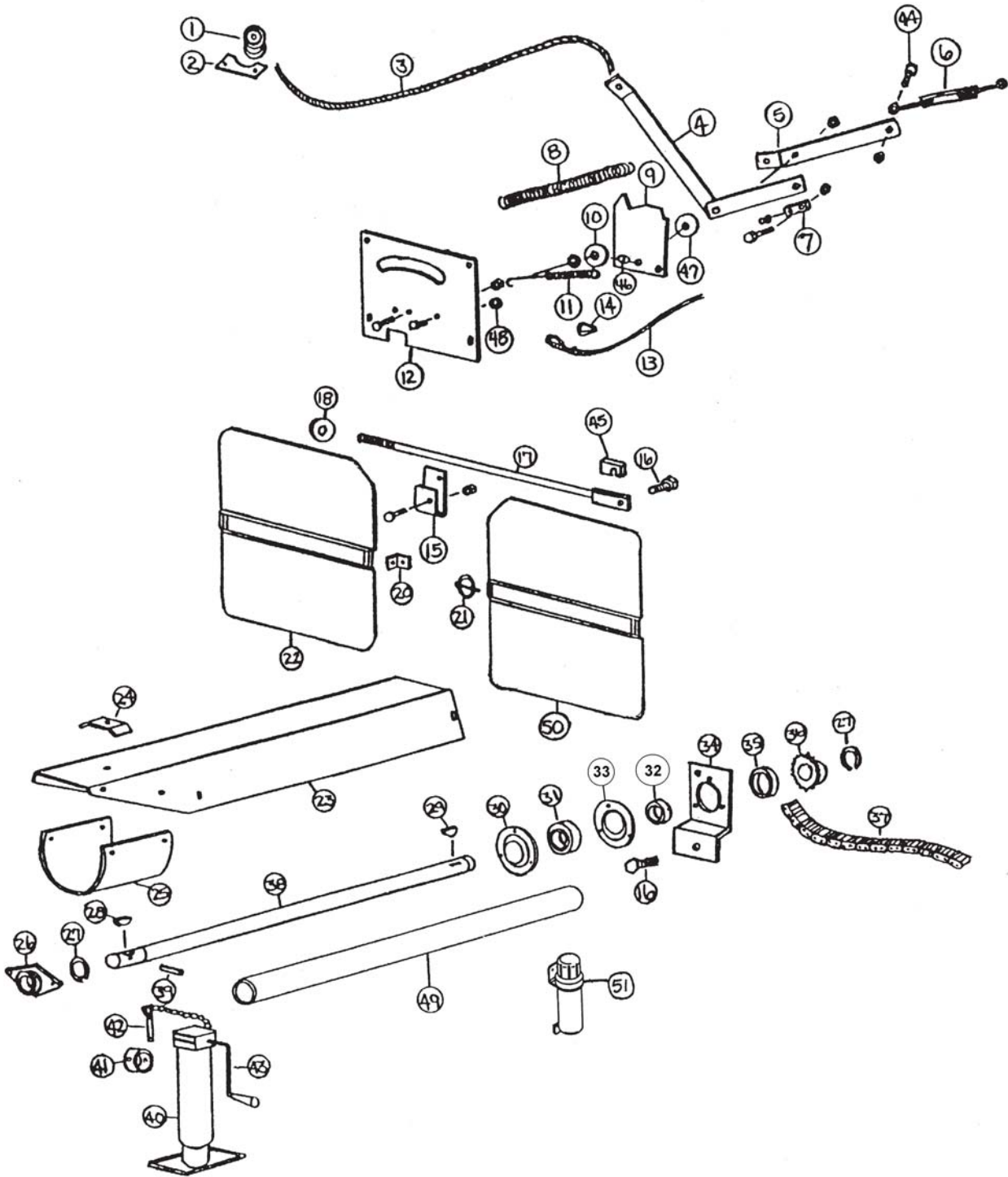

## FIGURE 3

### FRONT SHIELDS/DRIVE ASSEMBLY

<u>ITEM</u>	<u>235</u>	<u>270</u>	<u>DESCRIPTION</u>
28	5B10	"	1/4" X 1" KEY
29	5B9	"	3/8" X 1-1/4" WOODRUFF KEY
30	F114A	"	FLANGE, 1-1/4" W/45 DEG. ZERK
31	12N122	"	BEARING W/ LOCK COLLAR ASSY.
32	12N122	"	BEARING W/ LOCK COLLAR ASSY.
33	F14	"	BEARING FLANGE
34	23N68	"	FRONT ADJUSTMENT PLATE
35	23N69	"	SPACER
36	23N70	"	25 TOOTH SPROCKET
37	23N245	"	#60 ROLLER CHAIN 125 PITCHES
38	23N72	"	FRONT SHAFT
39	YPEX10020	"	EXPANSION PIN, 5/16" X 2-1/4"
40	12N116	27N49	JACK
*	12N120	"	JACK GEAR REP. KIT
41	12N121	27N51	JACK MOUNT
42	12N117	27N50	JACK PIN
43	12N119	"	HANDLE
*	12N118	"	REPLACEMENT BEARING
44	YBCR12010	"	CARRIAGE BOLT, 3/8" X 1" GR. 5
45	23N278	"	SPACER
46	23N297	"	ROLLER
47	S304	"	WASHER
48	ST81	"	SPACER (2)
49	37N74	"	FRONT SHAFT GUARD
50	23N306	"	FRONT SHIELD LH
51	S522	"	MANUAL HOLDER

**NOTE: " MEANS SAME AS PREVIOUS MODEL**

**\* MEANS NOT SHOWN**

# FIGURE 4

## BACK SHIELDS/DRIVE ASSEMBLY

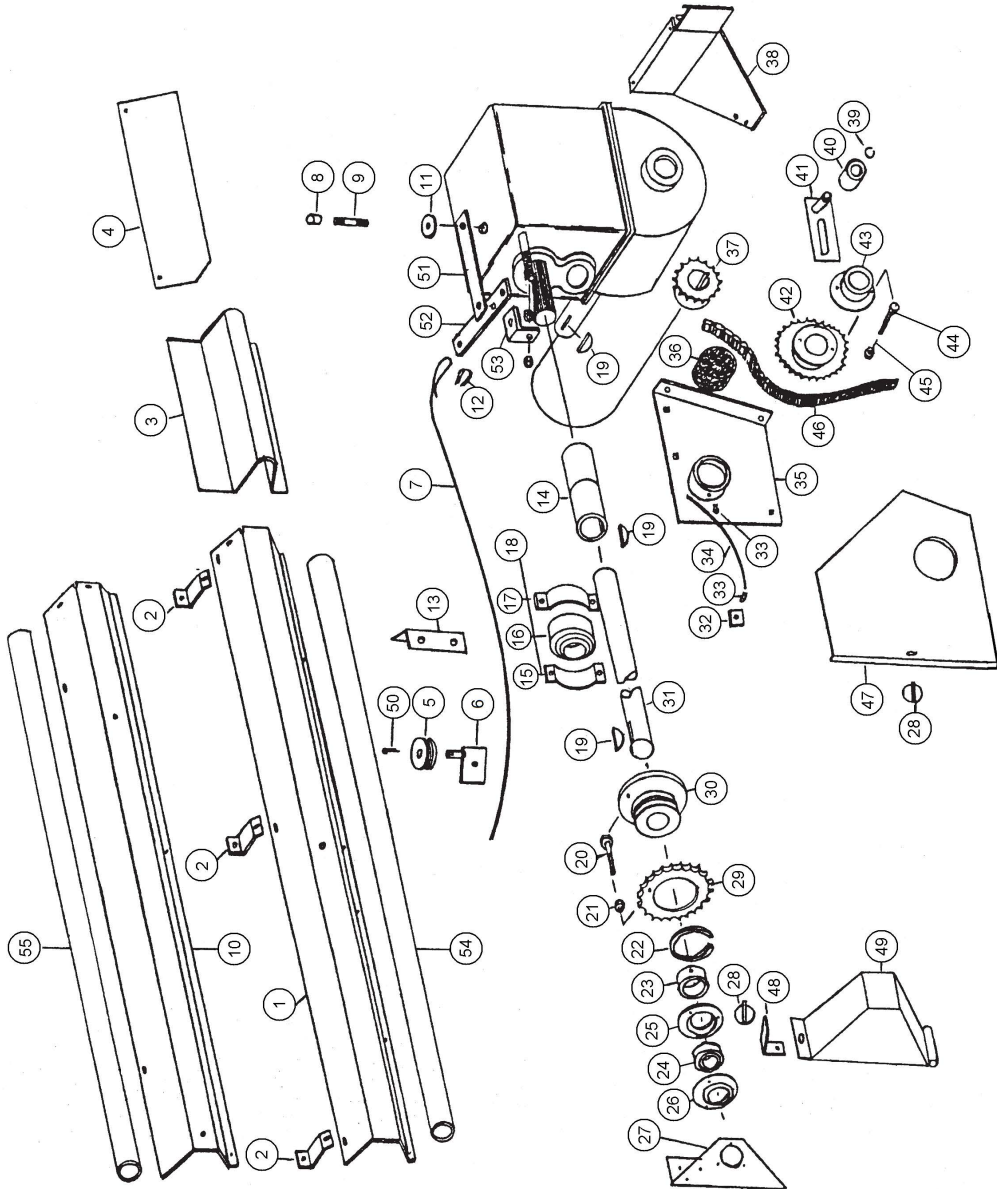

# FIGURE 4

## BACK SHIELDS/DRIVE ASSEMBLY

<u>ITEM</u>	<u>PART #</u>		<u>DESCRIPTION</u>
	<u>235</u>	<u>270</u>	
1	23N247	27N39	SIDE SHIELD
2	23N248	"	SIDE SHIELD BRACKET
3	23N292	"	COUPLER SHIELD
4	23N250	"	POLY SHIELD
5	23N251	"	POLY PULLEY
6	23N252	"	PULLEY MOUNT
7	23N253	27N32	CABLE
8	17G58	"	VENT CAP
9	23N288	"	PIPE NIPPLE
10	———	27N34	BACK SIDE SHIELD
11	17G61	"	WASHER
12	F44	"	CABLE LOOP
13	23N269	"	BEARING BRACKET
14	17G65	"	COUPLER
15	12N35	"	HOLDER
16	12N33	"	BEARING
17	12N34	"	BEARING COVER
18	12N36	"	COMPLETE ASSEMBLY
19	B59	"	3/8" X 1-1/4" WOODRUFF KEY
20	YBHH10030	"	BOLT, 5/16" X 1-1/2" GR. 5
21	YNTL10005	"	HEX NUT, TOP LOCK, 5/16"-18
22	23N189	"	SNAP RING
23	12N122	"	BEARING W/ LOCK COLLAR ASSY.
24	12N122	"	BEARING W/ LOCK COLLAR ASSY.
25	F114A	"	FLANGE
26	F14	"	BEARING FLANGE
27	23N254	"	SIDE BEARING PANEL
28	S122	"	LANYARD, CLIP PIN CABLE.
29	23N191	"	30 TOOTH SPROCKET
30	23N190	"	SHEAR HUB
31	23N255	27N33	SIDE SHAFT

**NOTE: " MEANS SAME AS PREVIOUS MODEL**  
**—— MEANS NOT USED**

# FIGURE 4

## BACK SHIELDS/DRIVE ASSEMBLY

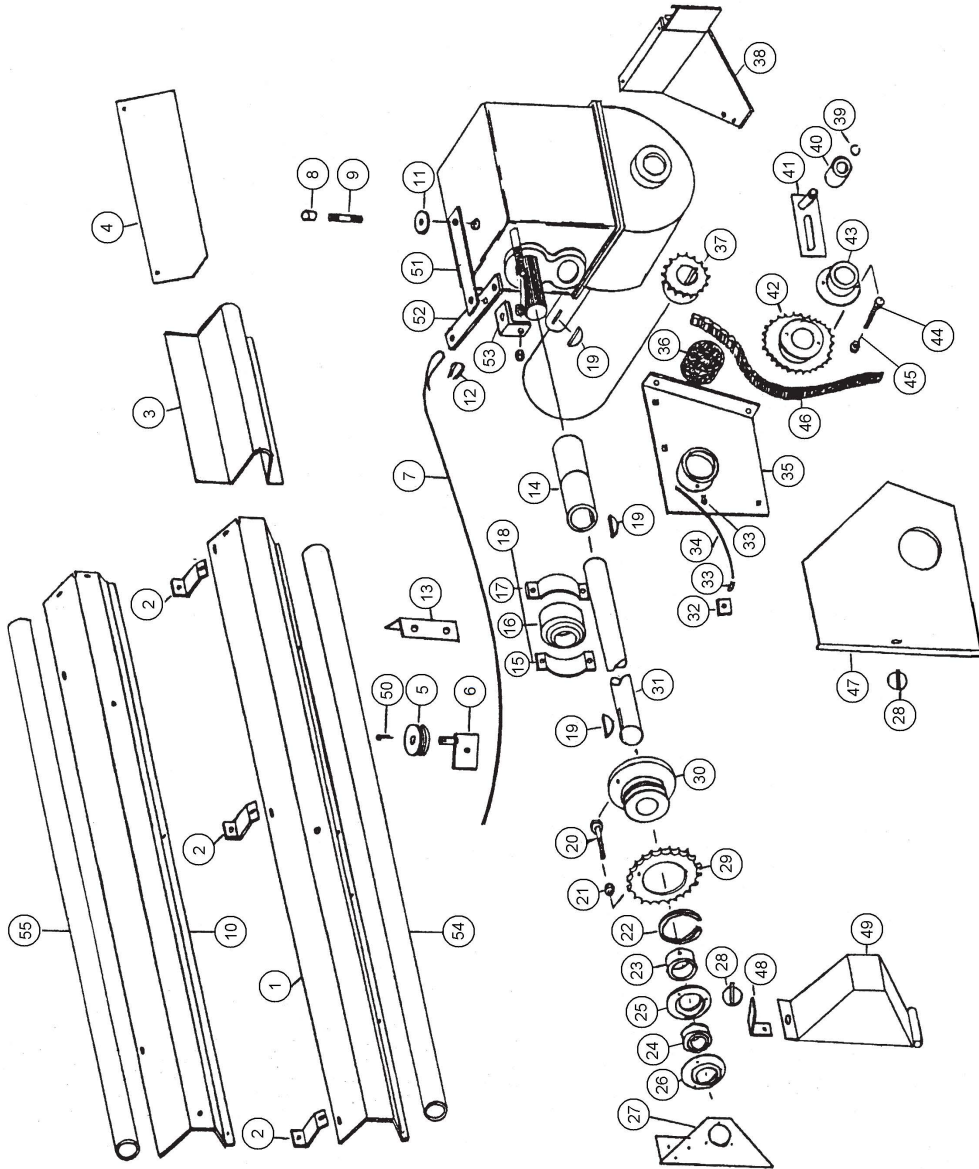



## FIGURE 4

### BACK SHIELDS/DRIVE ASSEMBLY

#### PART #

<u>ITEM</u>	<u>235</u>	<u>270</u>	<u>DESCRIPTION</u>
32	16V9	"	GREASE ZERK BLOCK
33	S47	"	GREASE LINE FITTING
34	23N256	"	GREASE LINE
35	23N257	"	LH DRIVE SHAFT MOUNT
36	23N258	"	CHAIN OILER
37	17G67	"	WORM GEAR SPROCKET
38	23N259	"	GEARBOX BRACE
39	10R32	"	SNAP RING
40	23N238	"	CHAIN TIGHTENER ROLLER
41	L10R35	"	CHAIN TIGHTENER BRACKET
42	17G68	"	SHEAR HUB SPROCKET - STANDARD (32T)
43	17G170	"	SLOW DOWN SPROCKET (40T)
*	23N279	"	SPEED UP SPROCKET (25T)
*	17G71	"	SHEAR HUB
44	YBHH10030	"	BOLT, 5/16" X 1-1/2" GR. 5
45	YNTL10005	"	HEX NUT, TOP LOCK, 5/16"-18
46	23N260	"	#60 CHAIN 56 PITCHES
47	23N261	"	DRIVE SHIELD
48	23N242	"	SHIELD ANGLE
49	22G21	"	SHIELD
50	YPCT04005	"	COTTER PIN, 1/8" X 1"
51	23N289	"	SHIFTER ROD LEVER FULCRUM SHIFTER
52	23N290	"	ROD LEVER
53	23N291	"	SHIFTER ROD ANGLE
54	23N294	27N41	1ST SIDE SHAFT GUARD
55	23N295	27N42	2ND SIDE SHAFT GUARD
*	———	27N43	3RD SIDE SHAFT GUARD
*	———	27N44	4TH SIDE SHAFT GUARD

**NOTE: " MEANS SAME AS PREVIOUS MODEL**

**\* MEANS NOT SHOWN**

**——— MEANS NOT USED**

**FIGURE 5**  
**HYDRAULIC ENDGATE ASSEMBLY**

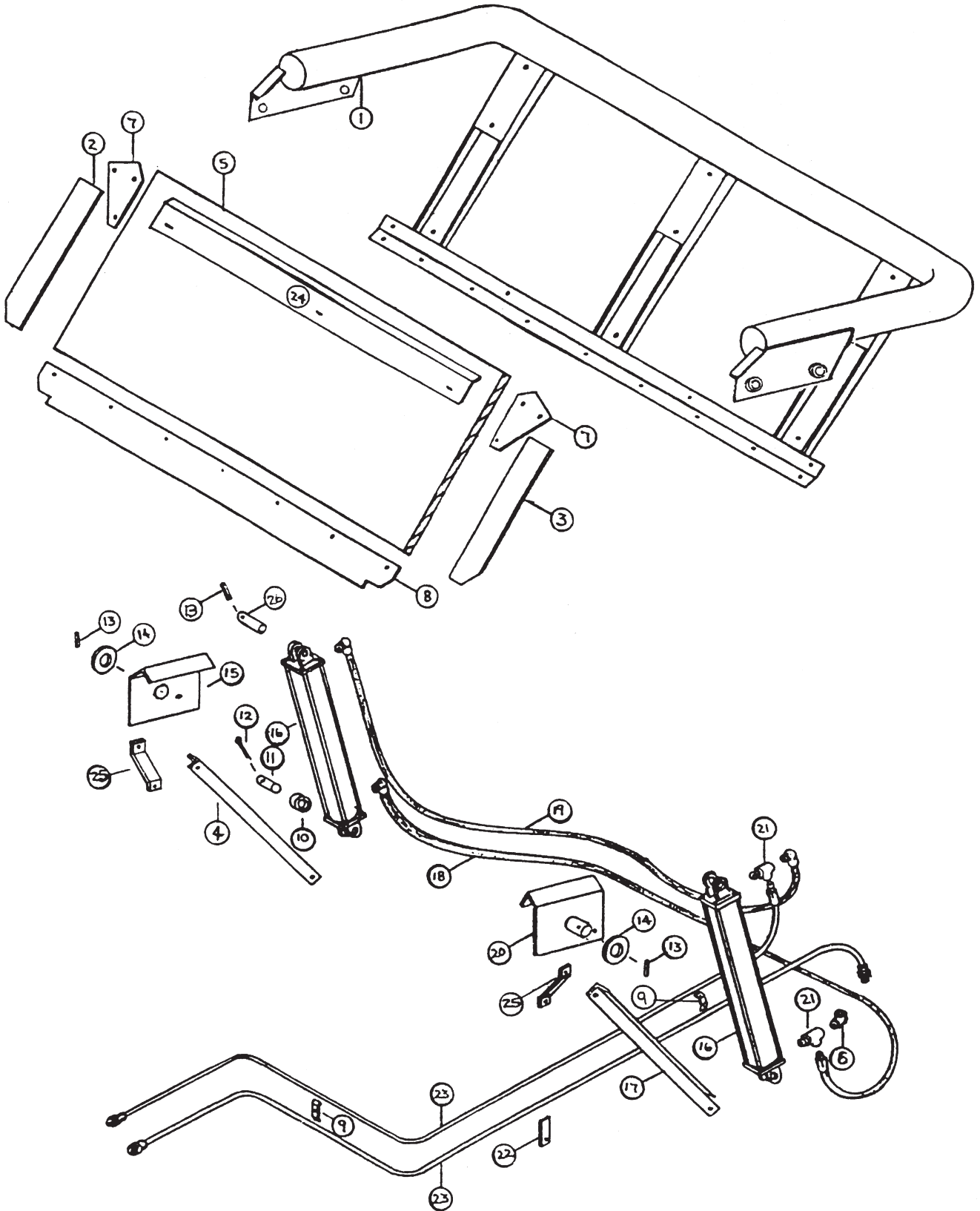

# FIGURE 5

## HYDRAULIC ENDGATE ASSEMBLY

### PART #

<u>ITEM</u>	<u>235</u>	<u>270</u>	<u>DESCRIPTION</u>
1	23N298	"	TAILGATE FRAME
2	23N99	"	RH SIDE RUBBER
3	23N100	"	LH SIDE RUBBER
4	23N233	"	TAILGATE BRACKET BRACE
5	23N274A	"	TAILGATE PLYWOOD WITH FIBERGLASS
6	23N234	"	90° STREET ELBOW 3/8"
7	23N104	"	TAILGATE CORNER
8	23N105	"	BOTTOM RUBBER
9	23N67	"	HOSE BRACKET
10	K132	"	SPACER
11	23N107	"	CYLINDER PIN
12	YPCT07005	"	COTTER PIN, 7/32" X 2"
13	YPEX10015	"	EXPANSION PIN, 5/16" X 1-3/4"
14	23N109	"	WASHER
15	23N299	"	RH TAILGATE MOUNT
16	23N111A	"	HYDRAULIC CYLINDER(235 SERIAL #413468/ 270 SERIAL #414155 AND PRIOR)
*	56015	"	2" X 16" HYDRAULIC CYLINDER(235 SERIAL #413469/ 270 SERIAL #414156 FOWARD)
17	23N231	"	BRACE
18	23N113	"	HOSE (96")
19	23N114	"	HOSE (138")
20	23N300	"	LH TAILGATE MOUNT
21	23N116	"	TEE
22	23N117	"	HOSE HOLDER
23	23N307	27N47	HOSE (23N307 - 274" / 27N47 - 298")
24	23N163	"	TAILGATE POLY HOLD DOWN
25	23N232	"	TAILGATE BRACKET BRACE
26	23N301	"	CYLINDER PIN

**NOTE: " MEANS SAME AS PREVIOUS MODEL**

# FIGURE 6

## APRON CHAIN ASSEMBLY

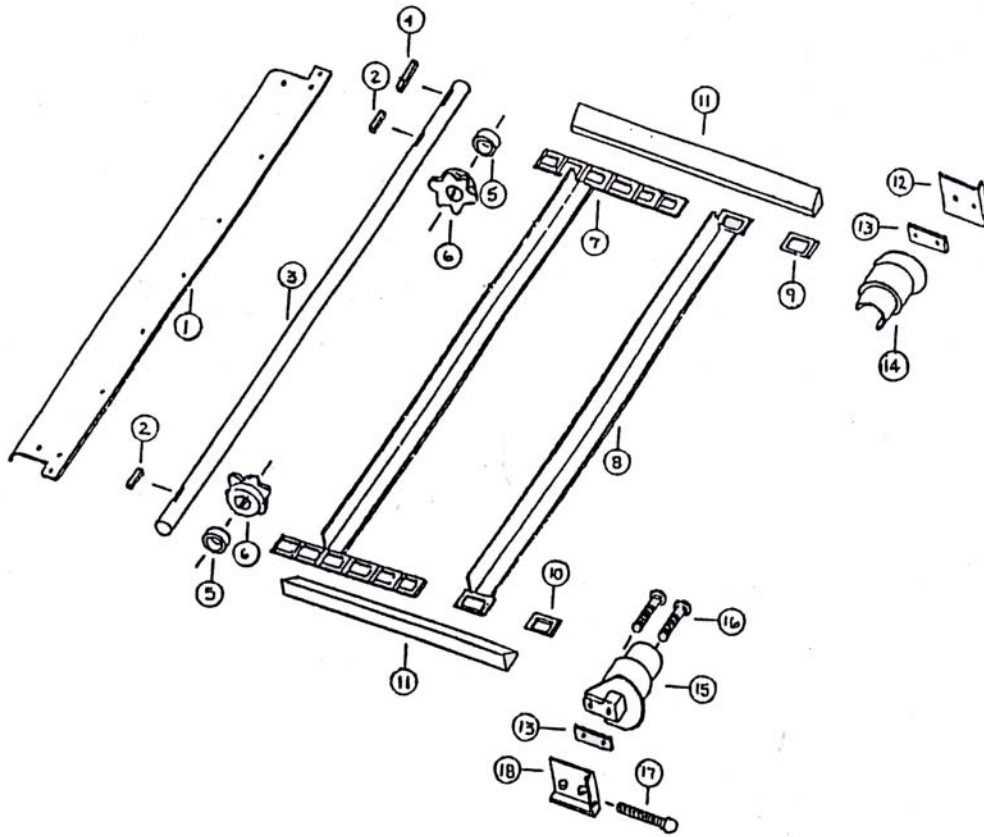

		<u>PART #</u>		
<u>ITEM</u>	<u>235</u>	<u>270</u>		<u>DESCRIPTION</u>
1	23N119	"		REAR POLY HOLD DOWN
2	23N303	"		3/8" X 1-3/4" SQUARE KEY
3	27N35	27N35		DRIVE SHAFT
4	A32	"		3/8" X 1-3/8" SQUARE KEY W/ ROUND ENDS
5	23N121	"		SPACER
6	23N122	"		DRIVE SPROCKET 6T
7	23N123	——		APRON CHAIN 17 SLATS, 210 LINKS
*	——	27N20		APRON CHAIN 20 SLATS, 244 LINKS
8	23N124	"		SLAT W/ ATTACHMENT LINK
9	S55	"		T-ROD STANDARD LINK
10	S56	"		T-ROD CHAIN SIDE SPACERS
11	23N125	27N21		APRON CHAIN SIDE SPACERS
12	A30	"		CHAIN SLIDE PLATE
13	23N126	"		CHAIN SLIDE SPACER
14	23N127	"		T-ROD SLIDE LH
15	23N128	"		T-ROD SLIDE RH
16	YBCR16045	"		CARRIAGE BOLT, 1/2" X 4" GR. 5
17	YBHH16140	"		BOLT, 1/2" X 4-1/2" GR. 5
18	A29	"		CHAIN SLIDE PLATE

**NOTE:** " MEANS SAME AS PREVIOUS MODEL

—— MEANS NOT SHOWN

# FIGURE 7

## HYDRAULIC ENDGATE CYLINDER

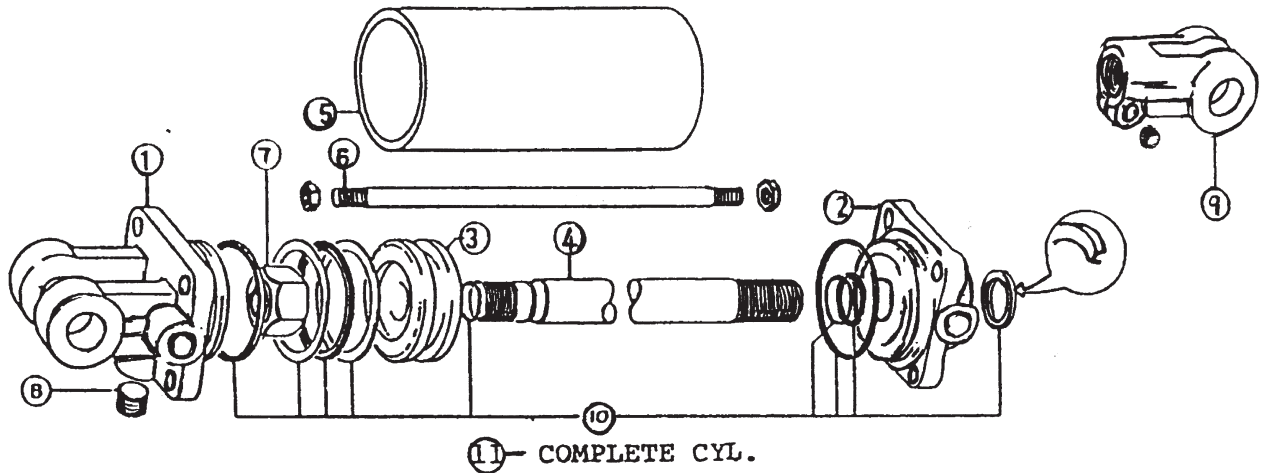

ITEM	PART #		DESCRIPTION
	235	270	
1	23N142A	"	CLEVIS CAP
2	23N143A	"	ROD CAP(235 SERIAL #413468/ 270 SERIAL #414155 AND PRIOR)
*	56174	"	ROD CAP(235 SERIAL #413469/ 270 SERIAL #414156 FOWARD)
3	23N144	"	PISTON(235 SERIAL #413468/ 270 SERIAL #414155 AND PRIOR)
*	56180	"	PISTON(235 SERIAL #413469/ 270 SERIAL #414156 FOWARD)
4	23N145A	"	ROD
5	23N146	"	CYLINDER TUBE
6	23N147	"	TIE ROD
7	23N148	"	PISTON NUT
8	23N149	"	PLUG
9	23N150A	"	ROD CLEVIS
10	23N151	"	SEAL KIT(235 SERIAL #413468/ 270 SERIAL #414155 AND PRIOR)
*	56187	"	SEAL KIT(235 SERIAL #413469/ 270 SERIAL #414156 FOWARD)
11	23N111A	"	HYDRAULIC CYLINDER COMPLETE(235 SERIAL #413468/ 270 SERIAL #414155 AND PRIOR)
*	56015	"	HYDRAULIC CYLINDER COMPLETE(235 SERIAL #413469/ 270 SERIAL #414156 FOWARD)

NOTE: " MEANS SAME AS PREVIOUS MODEL

# FIGURE 8

## PTO ASSEMBLY

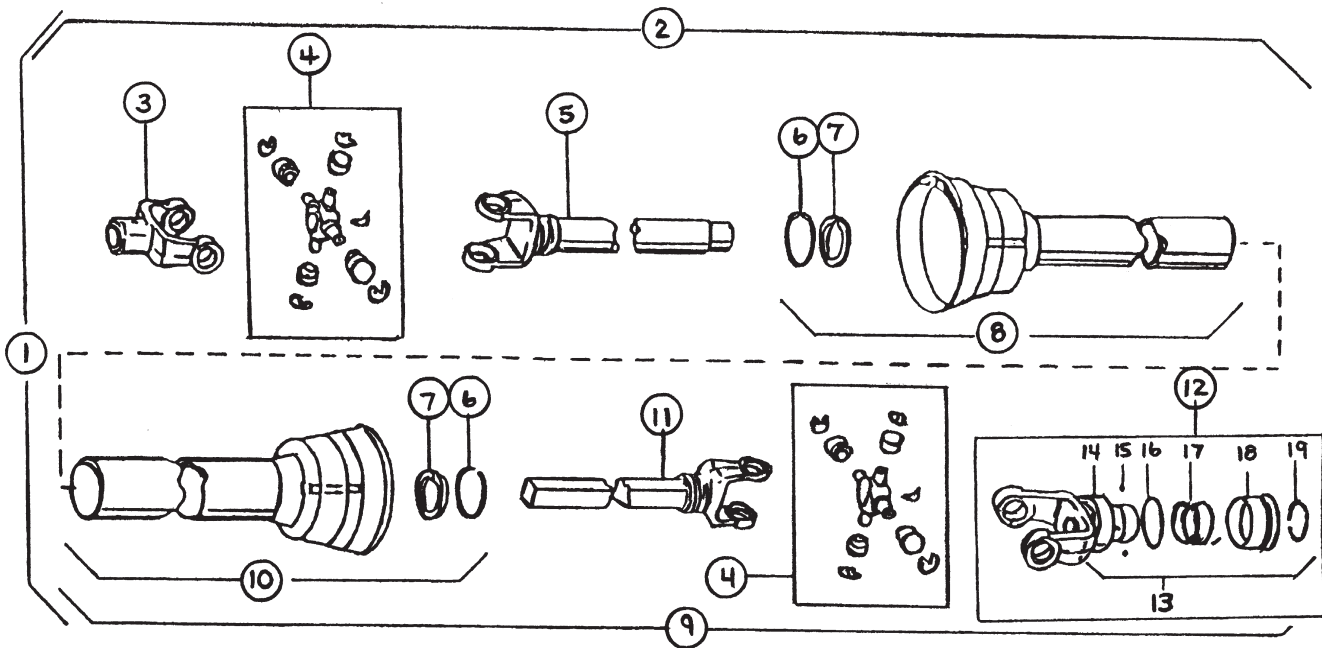

	<b>PART #</b>		<b>DESCRIPTION</b>
<b>ITEM</b>	<b>235</b>	<b>270</b>	
1	23N152	"	PTO ASSEMBLY COMPLETE W/ SHIELDS
2	23N153	"	MACHINE HALF PTO W/ SHIELD
3	G1R35	"	END YOKE MACHINE HALF
4	14NWKIT	"	REPAIR KIT
5	23N155	"	YOKE AND TUBE
6	24N26	"	BEARING RETAINER
7	4N20	"	NYLON BEARING
8	23N156	"	INNER GUARD INCLUDING ITEM #6 & #7
9	23N157	"	TRACTOR HALF PTO W/ SHIELD
10	23N158	"	OUTER GUARD INCLUDING ITEM #6 & #7
11	23N159	"	YOKE AND SHAFT
12	23N162	"	LOCK YOKE ASSEMBLY
13	S225	"	SPRING LOCK REPAIR KIT
14	S226	"	COVER
15	S212	"	STAINLESS BALL
16	S227	"	WASHER
17	S228	"	SPRING
18	S229	"	COLLAR ASSEMBLY
19	S215	"	RETAINING RING
*	S402	"	PTO SAFETY MANUAL

**NOTE: " MEANS SAME AS PREVIOUS MODEL**  
**\* MEANS NOT SHOWN**



# FIGURE 9

## OPTIONAL 2ND BEATER

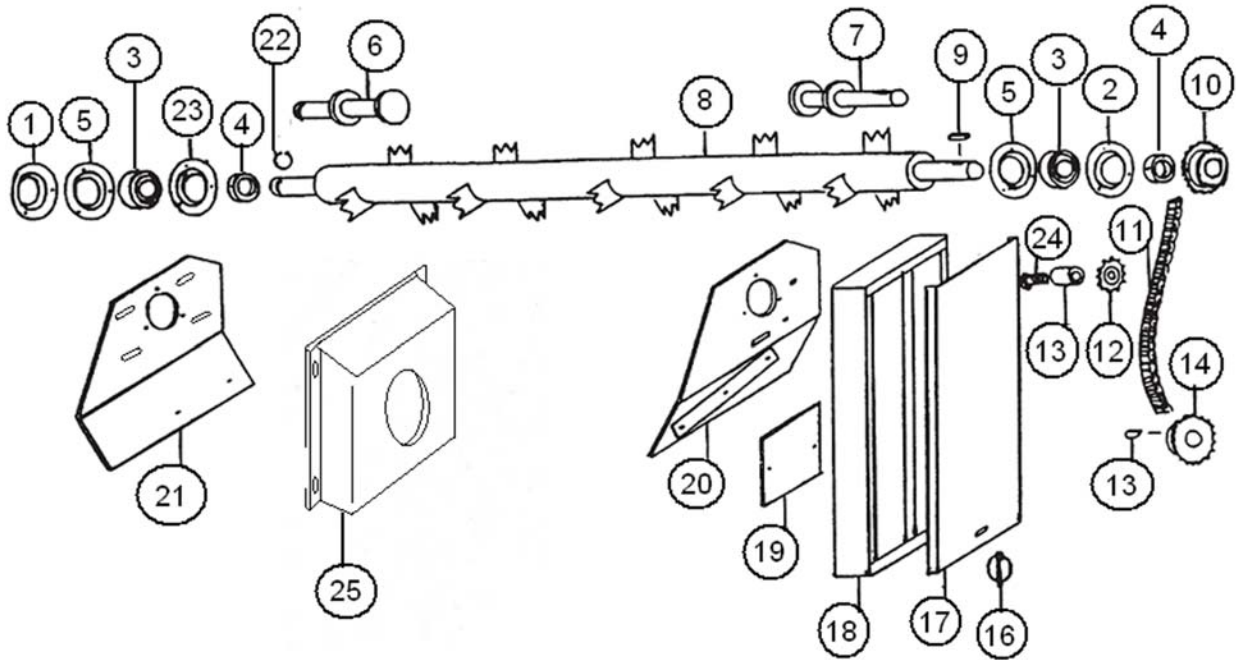

### PART #

<u>ITEM</u>	<u>235</u>	<u>270</u>	<u>DESCRIPTION</u>
1	23N308	"	BEARING FLANGE GUARD
2	F114A	"	BEARING FLANGE W/ ZERK - 45°
3	12N122	"	BEARING W/ LOCK COLLAR ASSY.
4	12N122	"	BEARING W/ LOCK COLLAR ASSY.
5	F14	"	BEARING FLANGE
6	23N164	"	LH STUB SHAFT
7	23N165	"	RH STUB SHAFT
8	23N166	"	2ND BEATER
9	G23	"	5/16" X 1-3/8" SQUARE KEY
10	D18	"	16T SPROCKET
11	23N167	"	#60 CHAING (81 PITCHES)
12	12N42	"	IDLER SPROCKET
13	23N168	"	SPACER
14	F13	"	20T SPROCKET
15	5B9	"	3/8" X 1-1/4" WOODRUFF KEY
16	YPLY08010	"	LYNCH PIN, 1/4" X 1-1/2"
17	23N169	"	COVER
18	23N170	"	SHIELD
19	23N171	"	SHIELD
20	23N172	"	RH PANEL
21	23N173	"	LH PANEL
22	F73	"	SNAP RING
23	F114A	"	FLANGE W/ STRAIGHT ZERK
24	YBCR16040	"	CARR. BOLT, 1/2" X 3-1/2" GR. 5
25	57216	"	BEATER BEARING PROTECTOR

**NOTE: " MEANS SAME AS PREVIOUS MODEL**

# FIGURE 10

## GEARBOX

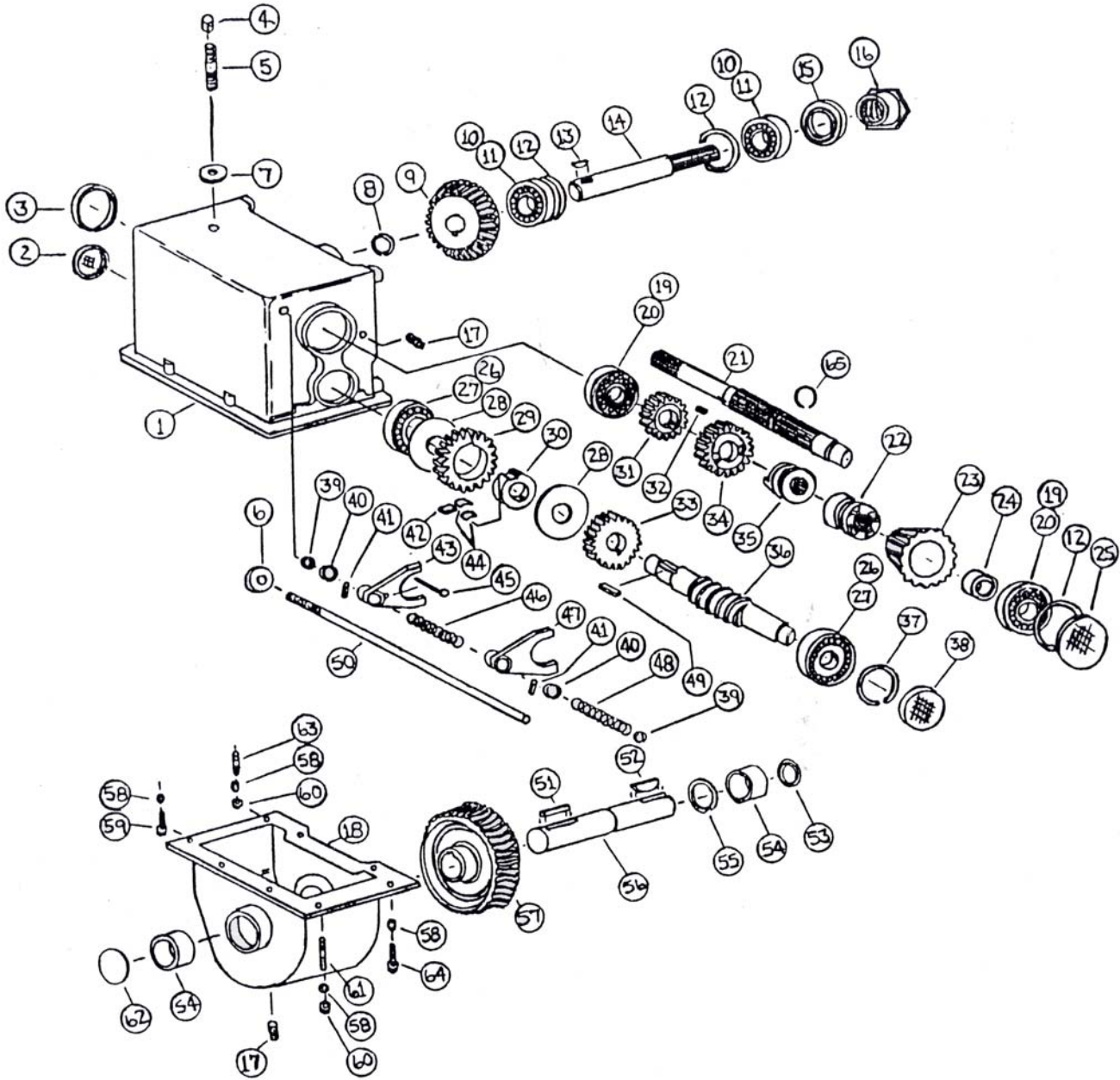

# FIGURE 10

## GEARBOX

<u>ITEM</u>	<u>235</u>	<u>270</u>	<u>DESCRIPTION</u>
1	17G99	"	UPPER GEAR HOUSING
2	17G100	"	CAP
3	S136	"	SEAL
4	17G58	"	VENT CAP
5	23N288	"	PIPE NIPPLE
6	17G171	"	COLLAR
7	17G61	"	WASHER
8	12V62	"	RETAINING RING
9	17G101	"	22T BEVELED GEAR
10	17G102	"	RACE 13621
11	17G103	"	BEARING 13685
12	G55	"	RETAINING RING
13	G61	"	3/8" X 1-1/4" HARDENED WOODRUFF KEY
14	17G104	"	BEATER OUTPUT SHAFT
15	17G105	"	SEAL
16	17G106	"	ADJUSTMENT NUT
17	G65	"	PLUG
18	17G107	"	LOWER GEAR HOUSING
19	G54	"	RACE 14276
20	G18	"	BEARING 14124
21	17G108A	"	INPUT SHAFT
22	17G109	"	BEATER CLUTCH
23	17G110	"	16T BEVELED GEAR W/ CLUTCH
24	17G111	"	BUSHING 1-1/2" ID X 1" LENGTH
25	G68	"	CAP
26	3G18	"	RACE 15245
27	L3G24	"	BEARING 15113
28	17G112	"	WASHER
29	17G113	"	32T GEAR W/ CLUTCH
30	17G114	"	GEAR HUB W/ CLUTCH
31	17G115	"	20T GEAR
32	17G116	"	1/4" X 5/8" KEY
33	17G117	"	24T GEAR

**NOTE: " MEANS SAME AS PREVIOUS MODEL**

**\* MEANS NOT SHOWN**

# FIGURE 10

# GEARBOX

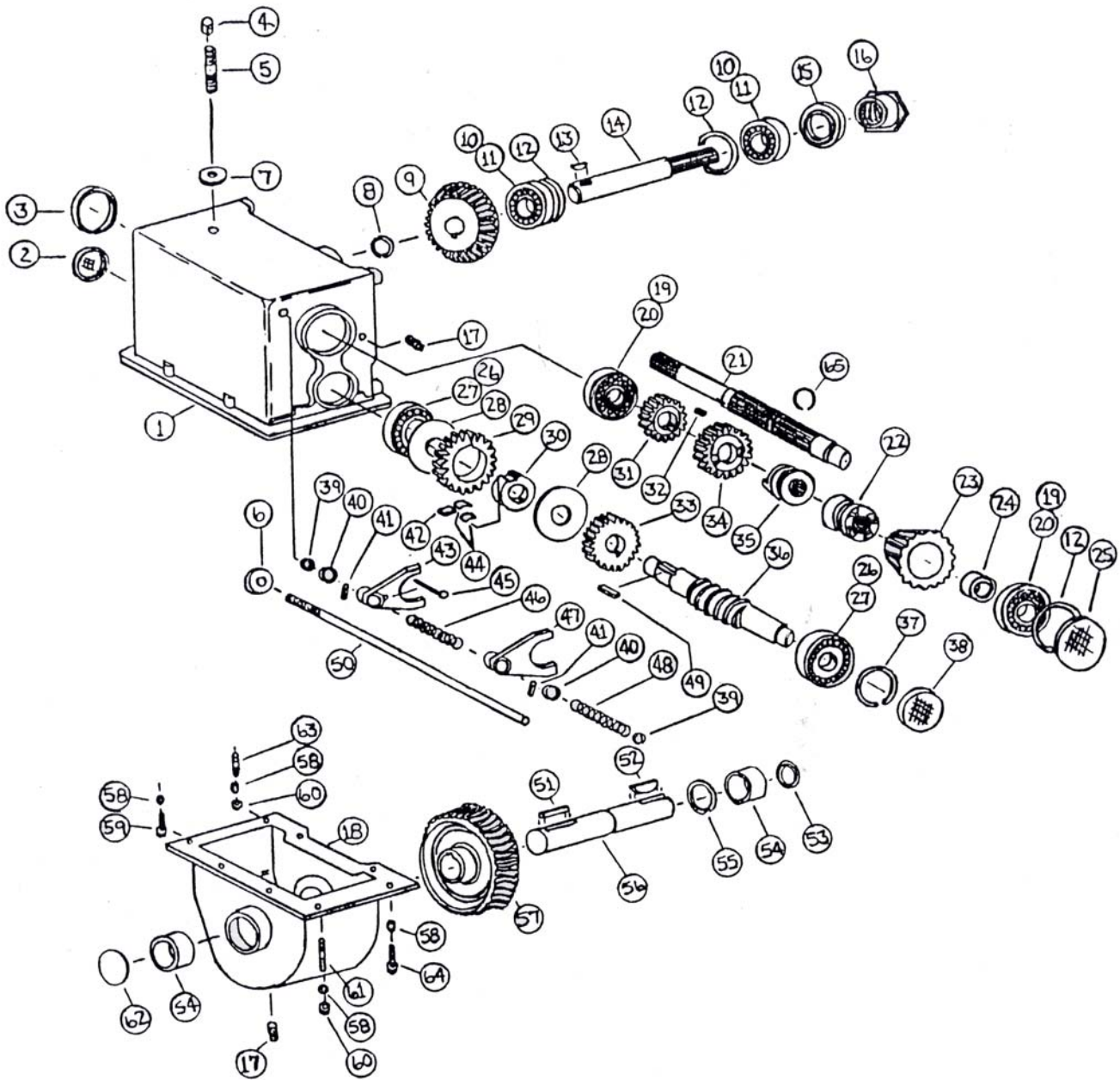

## FIGURE 10

### GEARBOX

<u>ITEM</u>	<u>235</u>	<u>270</u>	<u>DESCRIPTION</u>
34	17G118	"	28T GEAR W/ CLUTCH
35	17G119	"	HIGH SPEED CLUTCH
36	17G120	"	WORM SHAFT
37	3G19	"	RETAINING RING
38	G90	"	CAP
39	17G121	"	SEAL
40	17G122	"	SPACER
41	17G123	"	3/16" X 1" ROLL PIN
42	17G124	"	CLUTCH DOG
43	17G125	"	HIGH SPEED SHIFTER YOKE
44	17G126	"	DOG SPRING/LOW SPEED CLUTCH
45	YBHH08090	"	BOLT, 1/4" X 3" GR. 2 FULL THREAD
46	17G128	"	SPRING/BEATER ENGAGE
47	17G129	"	BEATER SHIFTER YOKE
48	17G130	"	SPRING/BEATER DISENGAGE
49	S135	"	1/4" X 1-1/4" KEY
50	17G131	"	SHIFTER ROD
51	17G132	"	5/16" X 2-1/4" KEY
52	5B9	"	3/8" X 1-1/4" WOODRUFF KEY
53	17G133	"	SEAL
54	17G134	"	BUSHING, 1-1/2"ID X 1-1/2"
55	17G135	"	RETAINING RING
56	17G136	"	WORM GEAR OUTPUT SHAFT
57	17G137	"	WORM GEAR
58	YWLO12005	"	WASHER, LOCK, 3/8"
59	YBHH12010	"	BOLT, 3/8" X 1" GR. 5
60	YNHX12005	"	HEX NUT, 3/8"-16
61	17G138	"	3/8" X 2" STUD
62	17G139	"	1-3/4" CAP
63	17G140	"	3/8" X 1-1/2" STUD
64	YBHH12035	"	BOLT, 3/8" X 1-1/4" GR. 5
65	17G169A	"	SNAP RING
*	17G142	"	COMPLETE GEARBOX

**NOTE: " MEANS SAME AS PREVIOUS MODEL**

**\* MEANS NOT SHOWN**

**FIGURE 11**  
**4-HOSE HYDRAULIC DRIVE**

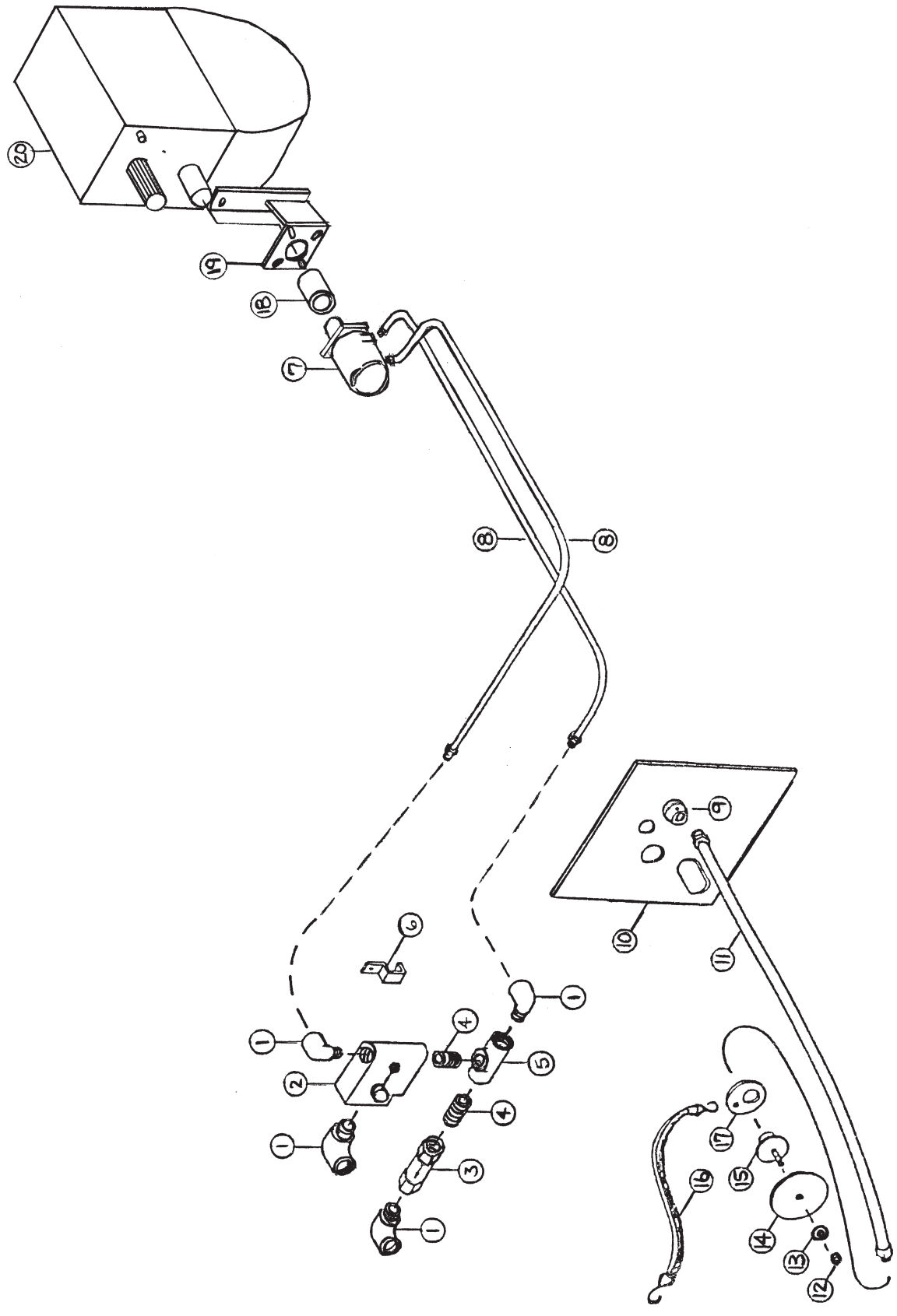



# FIGURE 11

## 4-HOSE HYDRAULIC DRIVE

<u>ITEM</u>	<u>PART #</u>		<u>DESCRIPTION</u>
	<u>235</u>	<u>270</u>	
1	HE58	"	90 DEGREE STREET ELBOW
2	DF15	"	SPEED CONTROL
3	DF18	"	CHECK VALVE
4	DF7	"	NIPPLE
5	DF8	"	TEE
6	HE14	"	HOSE BRACKET
7	DF1	"	HYDRAULIC MOTOR
8	23N132	"	HYDRAULIC MOTOR HOSE
9	DF21	"	REDUCER
10	23N133	"	CONTROL PANEL
11	DF9	"	HOSE FOR HANDLE
12	YNTL12005	"	HEX NUT, TOP LOCK, 3/8"-16
13	DF12	"	WASHER
14	DF11	"	HANDLE
15	DF10	"	HANDLE BRACKET
16	DF14	"	STRAP
17	DF22	"	RING FOR STRAP
18	17G161	"	COUPLER
19	17G162	"	MOUNTING BRACKET
20	17G163	"	COMPLETE GEARBOX

**NOTE: " MEANS SAME AS PREVIOUS MODEL**

**FIGURE 12**  
**2-HOSE HYDRAULIC DRIVE**

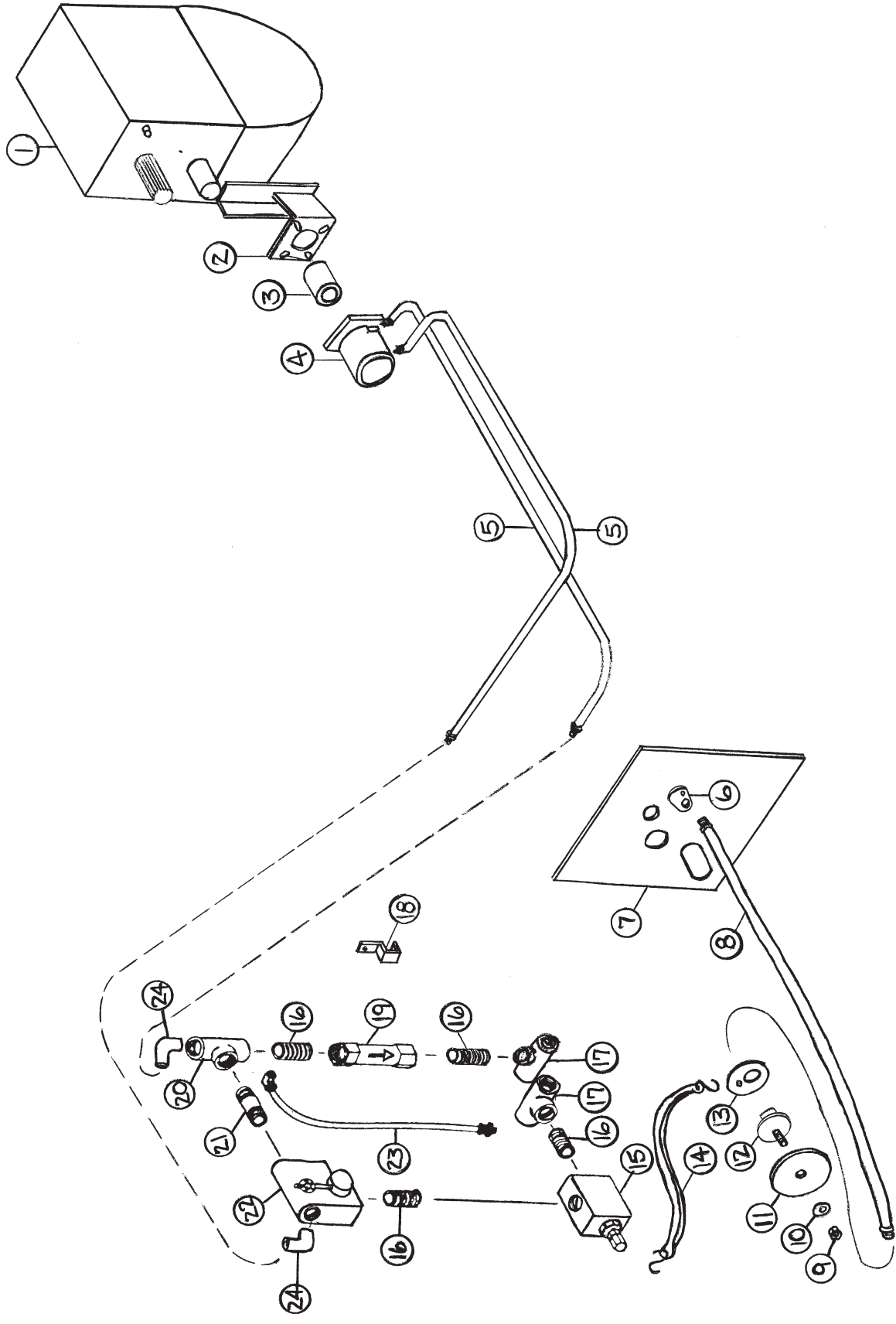

## **FIGURE 12**

### **2-HOSE HYDRAULIC DRIVE**

<b><u>ITEM</u></b>	<b><u>235</u></b>	<b><u>270</u></b>	<b><u>DESCRIPTION</u></b>
1	17G163	"	COMPLETE GEARBOX
2	17G162	"	MOUNTING BRACKET
3	17G161	"	COUPLER
4	DF1	"	HYDRAULIC MOTOR
5	23N132	"	HYDRAULIC MOTOR HOSE
6	DF21	"	REDUCER
7	23N133	"	CONTROL PANEL
8	DF9	"	HOSE FOR HANDLE
9	YNTL12005	"	HEX NUT, TOP LOCK, 3/8"-16
10	DF12	"	WASHER
11	DF11	"	HANDLE
12	DF10	"	HANDLE BRACKET
13	DF22	"	RING FOR STRAP
14	DF14	"	STRAP
15	DF6	"	SEQUENCE VALVE
16	DF7	"	NIPPLE
17	DF8	"	TEE
18	HE14	"	HOSE BRACKET
19	DF18	"	CHECK VALVE
20	DF19	"	TEE
21	DF17	"	NIPPLE
22	DF15	"	SPEED CONTROL
23	DF16	"	DRAIN HOSE
24	HE58	"	90 DEGREE STREET ELBOW

**NOTE: " MEANS SAME AS PREVIOUS MODEL**

# FIGURE 13

## HYDRAULIC DRIVE GEARBOX

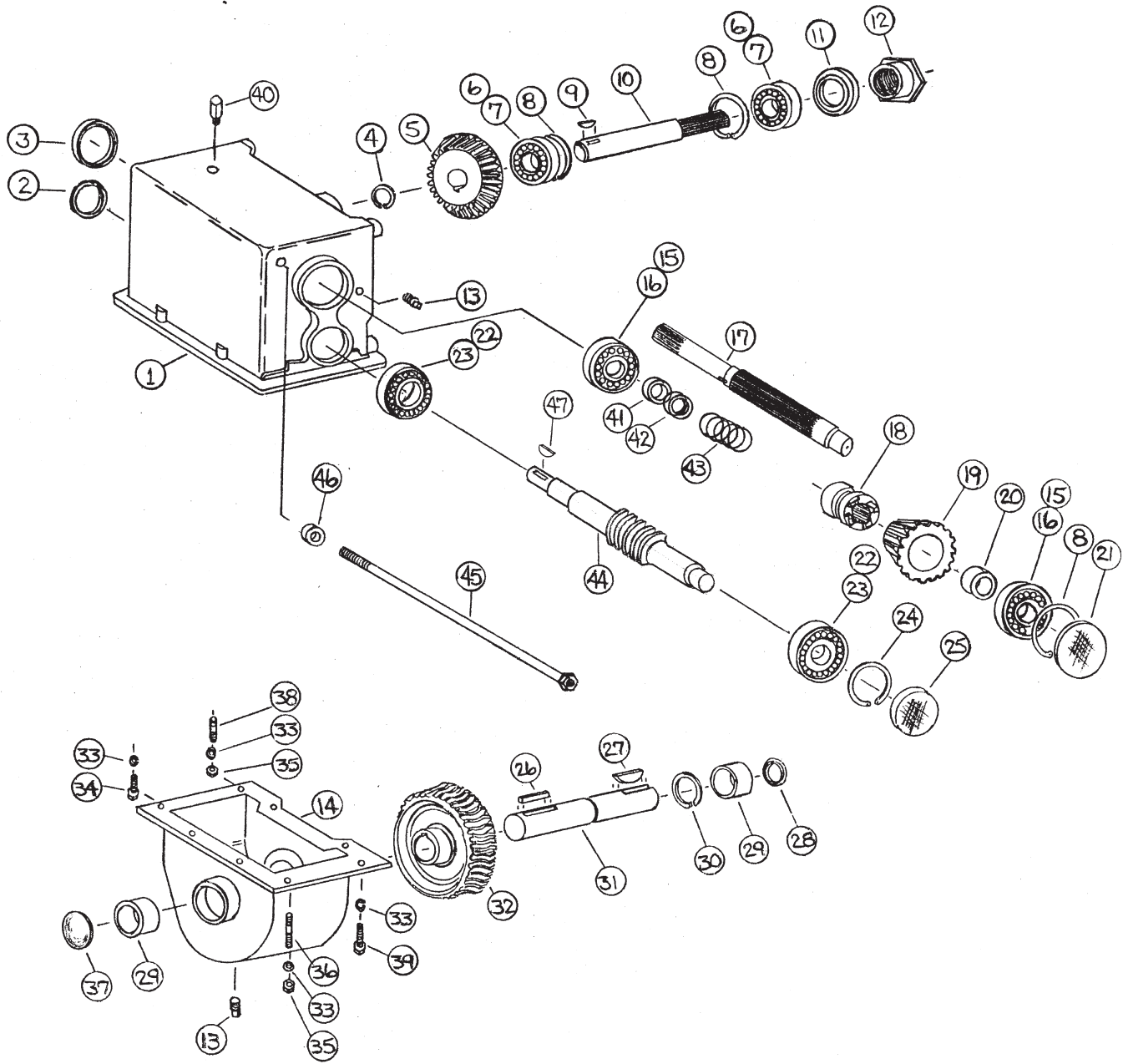

# FIGURE 13

## HYDRAULIC DRIVE GEARBOX

<u>ITEM</u>	<u>PART #</u>		<u>DESCRIPTION</u>
	<u>235</u>	<u>270</u>	
1	17G99	"	UPPER GEAR HOUSING
2	17G164	"	SEAL
3	S136	"	SEAL
4	12V62	"	RETAINING RING
5	17G101	"	22T BEVELED GEAR
6	17G102	"	RACE 13621
7	17G103	"	BEARING 13685
8	G55	"	RETAINING RING
9	G61	"	3/8" X 1-1/4" HARDENED WOODRUFF KEY
10	17G104	"	BEATER OUTPUT SHAFT
11	17G105	"	SEAL
12	17G106	"	ADJUSTMENT NUT
13	G65	"	PLUG
14	17G107	"	LOWER GEAR HOUSING
15	G54	"	RACE 14276
16	G18	"	BEARING 14124
17	17G108A	"	INPUT SHAFT
18	17G109	"	BEATER CLUTCH
19	17G110	"	16T BEVELED GEAR W/ CLUTCH
20	17G111	"	BUSHING 1-1/2" ID X 1" LENGTH
21	G68	"	CAP
22	3G18	"	RACE 15245
23	L3G24	"	BEARING 15113
24	3G19	"	RETAINING RING
25	G90	"	CAP
26	17G132	"	5/16" X 2-1/4" KEY
27	5B9	"	3/8" X 1-1/4" WOODRUFF KEY
28	17G133	"	SEAL
29	17G134	"	BUSHING 1-1/2" ID X 1-1/2" LENGTH
30	17G135	"	RETAINING RING
31	17G136	"	WORM GEAR OUTPUT SHAFT
32	17G137	"	WORM GEAR
33	YWLO12005	"	WASHER, LOCK, 3/8"
34	YBHH12010	"	BOLT, 3/8" X 1" GR. 5
35	YNHX12005	"	HEX NUT, 3/8"-16
36	17G138	"	3/8" X 2" STUD
37	17G139	"	1-3/4" CAP
38	17G140	"	3/8" X 1-1/2" STUD
39	YBHH12035	"	BOLT, 3/8" X 1-1/4" GR. 5
40	G24	"	VENT PIPE PLUG
41	17G165	"	5/8" SPACER
42	A25	"	1" SPACER
43	23N89	"	CLUTCH SPRING
44	17G166	"	WORM SHAFT
45	17G167	"	BOLT
46	17G168	"	3/4" SPACER
	5B10	"	1/4" X 1" KEY

**NOTE: " MEANS SAME AS PREVIOUS MODEL**







# H&S MFG. CO.

products approved

for the

## FEMA

# SEAL OF QUALITY

